

PMM-6P

Zone Module

Description

PMM-6P zone module is an intelligent addressable bus module.

PMM-6P is connected with fire alarm system to monitor the traditional two-wire detector and feed its status back to the controller.

The LED indicator of PMM-6P can be in the state of blinking, steady on or off according to the command issued by the fire alarm system. The indicator light is blinking when in normal communication, steady on when activated, and can be disabled off when special needs.

The communication line of the module adopts non-polarity wiring design, which is convenient for on-site wiring installation.



Specifications

Rated Voltage: DC24V.

Standby Current: 410µA@DC24V.

External Supply Voltage: DC24V.

Standby Current: 8.5mA@DC24V.

Alarm Current: 60mA@DC24V.

Operating Temperature: -10°C ~ 55°C.

Operating Humidity: 5% ~ 95%RH Non-condensing.

Dimension: 90mm×86mm×40mm (Including base).

Weight: 55g.

Software Version: A.

Carried Standard: GB 16806-2006.

Addressing

PMM-6P zone module is an intelligent module, each module in the loop must be addressed, its address is set by handheld programmer CP600M, address range: 1~230. Please refer to the handheld programmer CP600M instructions for specific operations.

Terminal Description

PMM-6P zone module is used with M600-6T module base, and its wiring terminals are defined as follows:

L1	Communication	O+	Z+
L2	Communication	VI1	Power
K1	No	VI2	Power
K2	No	NO	No
COM	Z-	O-	No

Power Supply and Wiring

Power supply instruction

The design of the system is determined by calculated number of modules allowed in the loop according to the load capacity of the controller or power supply, ensuring that the sum of the current consumed by all devices in the loop does not exceed the load capacity of the controller or power supply. In the loop calculation, it is necessary to consider the voltage drop caused by the resistance of the line.

Resistance of general wiring sizes

- 1.0 mm² 19.5Ω/1000m
- 1.5 mm² 13.3Ω/1000m
- 2.5 mm² 7.98Ω/1000m

For example, if there are 10 devices in a certain area and each device needs 10mA, connect them with 1.5mm² lines of 2000m (total line length = line length in operation + line length returned), and the current at the end of the line is 10mA, then: Number of devices x terminal current x (total length of lines x wire resistivity) = voltage drop, 10 x 10 mA x (2000m x 13.3 ohms /1000m) ≈ 2.7V

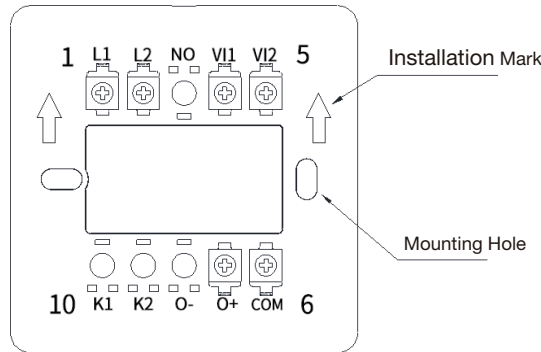

Figure 1: M600-6T Module Base

Wiring

PMM-6P zone module is used with M600-6T module base, wiring as shown in Figure 2.

Mounting

Install the base at the predetermined installation position according to the direction indicated by the installation mark (Figure 1) on the M600-6T module base.

Disconnect the power supply of the loop and wire according to the wiring diagram (Figure 2).

Use the handheld programmer CP600M to address the module.

Align the hook on the module with that on the base, press into the mounting base (Figure 3), and the installation is complete.

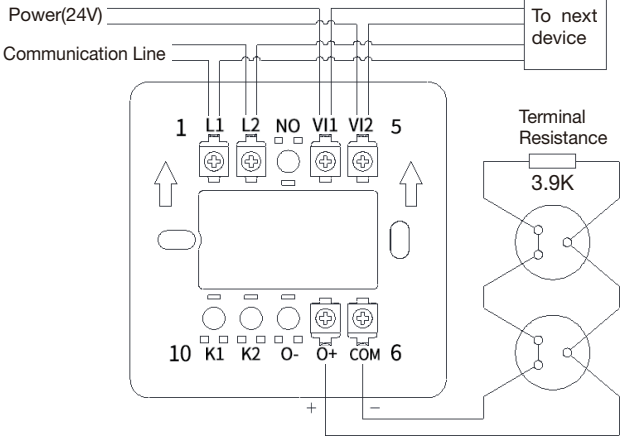

Figure 2: Wiring Diagram

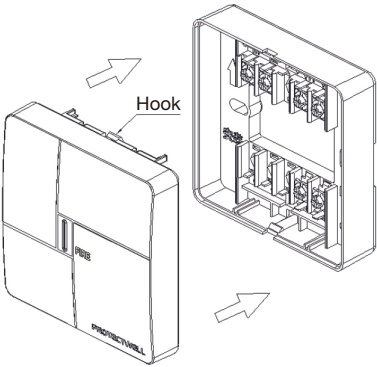

Figure 3: Mounting

Remove

As shown in Figure 4, insert the straight screwdriver into the removal hole and pry the base with moderate force in the direction of the arrow until the latch is released. Repeat this operation on the opposite side to remove the module.

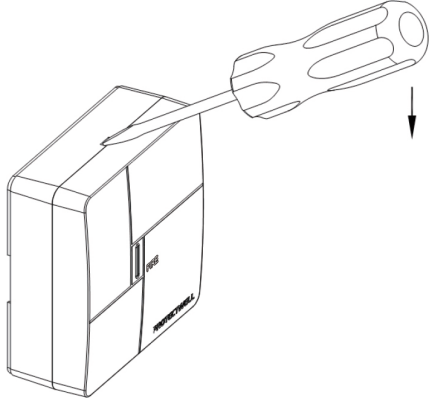

Figure 4: Remove